

The 1550 nm Forward Transmitter - Externally Modulated (FT5X) is designed to plug into PBN's latest Advanced Intelligent Multi-services Access platform (AIMA3000). PBN's wavelength-tunable FT5X series is available in dual and quad transmitter variants.

This series of modules includes Monolithic Distributed Bragg Reflector (DBR) laser with a Silicon Optical Amplifier and an Indium- Phosphide (InP) Mach-Zehnder Modulator provide AIMA with a cost-effective system for 1550 nm transmissions for DWDM applications when used for optical ITU frequency grids.

PBN's AIMA3000 FT5X series transmitter is designed for multi-services operators (MSOs) to increase network capacity to satisfy an ever-growing subscriber demand for more bandwidth. The FT5X can be used with Erbium Doped Fiber Amplifiers (EDFA) in short haul Fiber-to-the-Home (FTTH) applications and medium haul setups with a high RF performance of up to 60 km.

All FT5X models can also be conveniently monitored and controlled through a computer connected to one of the Ethernet ports via the ASMM module. All module settings are retained in non-volatile memory to ensure trouble-free operation. Bulk updating, automatic uploading and downloading of configuration files can be done when using PBN's NMSE web-based management system.



Key Features and Functions

- Plug-and-play AIMA3000 platform module with up to 4 independent forward path transmitters
- Suitable for DWDM applications supporting ITU optical frequency grid wavelength channels 21 to 51 (1560.61 nm to 1536.61 nm)
- Tunable wavelength between channel 21 and 51 in 200 GHz increments, reducing the quantity of transmitters at different fixed wavelengths
- All-digital QAM loading from 45 MHz to 1218 MHz
- Link distance of up to 60 kilometers without any dispersion compensation required
- High-density up to 64 transmitters in a 4RU chassis
- Automatic gain control (AGC) for a consistent optical modulation index (OMI)
- Automatic laser power control for consistent optical output
- Comprehensive alarm reporting and monitoring
- Remote firmware upgrade and auto upload/download of configuration files through ASMM web interface or using PBN's NMSE
- Fully FCC, CE, and RCM compliant

Block Diagram

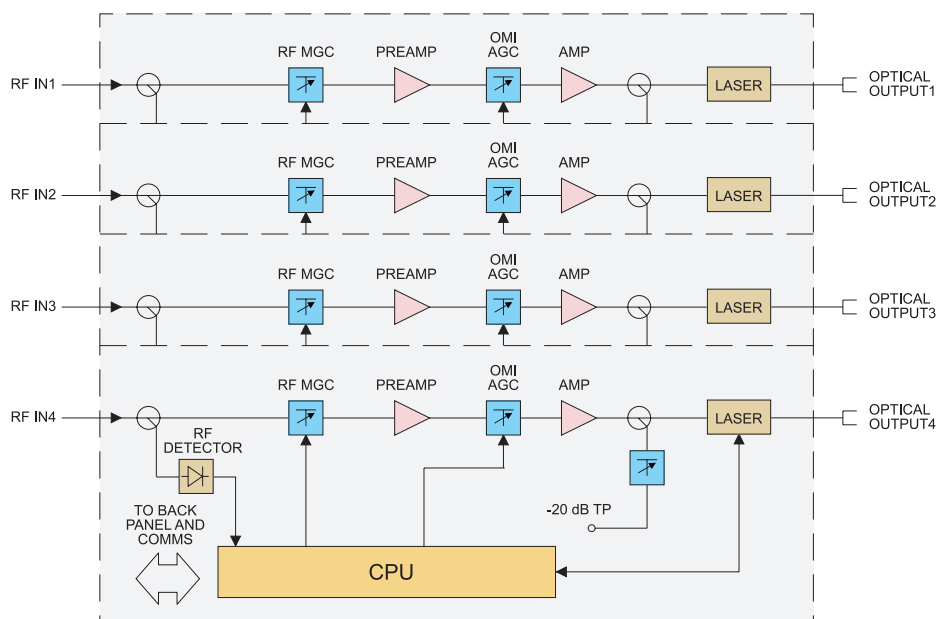

Specifications

Optical Performance

Optical wavelength ⁽¹⁾	Tunable/Fixed ITU DWDM Channels 21 to 51 (1560.61 nm to 1536.61 nm)
Optical outputs	2 or 4
Optical output power per port	5 dBm 6 dBm (fixed wavelength only)
Optical connector	SC/APC ⁽²⁾ , FC/APC, LC/APC, E2000/APC
Center Wavelength Spacing	200 GHz
SBS Suppression	+13 dBm

RF Performance

RF bandwidth	45 MHz to 1218 MHz
RF flatness	± 0.75 dB
RF input return loss	> 16 dB
RF nominal input level ⁽³⁾	15 dBmV per channel
AGC range	±3 dB
RF impedance	75 Ω
Laser input RF level test point	-20 dB ± 1 dB relative to laser input
RF connectors	Dual: 2 x GSK-type female Quad: 4 x GSK-type female
RF test points	Dual: 2 x Mini-SMB ⁽⁴⁾ Quad: 4 x Mini-SMB ⁽⁴⁾
Alarms and laser status	Front-panel LEDs, SNMP Traps

Link Performance⁽⁵⁾

MER	> 38 dB
BER	< 1E-9

General

Power supply	Powered via AIMA3000 backplane
Power consumption	Dual: < 13.0 W Quad: < 25.0 W
Operating temperature	-5°C to +50°C
Storage temperature	-25°C to +70°C
Dimensions (WxDxH)	24.6 x 410 x 152.5 mm
Weight	Dual: 0.88 kg Quad: 1.1 kg
Supported network management options	PBN's NMSE or through ASMM's Web Interface

Note:

- (1) Tunable version. The factory default ITU optical channel is 33 and the ITU optical channel can be changed via the Web GUI .
- (2) Standard option. Contact a PBN Sales Representative for availability of other options.
- (3) dBuV=60+dBmV
- (4) Two/Four mini-SMB connectors on front panel to measure the RF input before the laser transmitter.
- (5) MER and BER are tested with 117 QAM256 (301.25 MHz ~ 997.25MHz). All are measured with PBN referenced optical receiver with 20 km single-mode optical fiber 0 dBm.

Order Details

A-FT5X-[V]-[W]-[X1X2]-[Y]-[Z] | 1550 nm Forward Transmitter - Externally Modulated

Options:

<p>V Optical Ports</p> <p>D Dual (2)</p> <p>Q Quad (4)</p>	<p>Y Optical Connector Type</p> <p>S SC/APC</p> <p>F FC/APC</p> <p>L LC/APC</p> <p>E E2000/APC</p>
<p>W Optical Output Power Per Port</p> <p>06 6 dBm (4 mW) (fixed wavelength only)</p>	<p>Z Bandwidth</p> <p>12 45 ~ 1218 MHz</p>
<p>X1X2⁽¹⁾⁽²⁾ First Channel Last Channel</p> <p>21 192.1 THz (1560.61 nm)</p> <p>23 192.3 THz (1558.98 nm)</p> <p>25 192.5 THz (1557.36 nm)</p> <p>27 192.7 THz (1555.75 nm)</p> <p>29 192.9 THz (1554.13 nm)</p> <p>31 193.1 THz (1552.52 nm)</p> <p>33 193.3 THz (1550.92 nm)</p> <p>35 193.5 THz (1549.32 nm)</p> <p>⋮</p> <p>51 195.1 THz (1536.61 nm)</p> <p>T⁽³⁾ Tunable</p>	

Note:

- (1) Default spacing is 200 GHz. For other wavelength configurations not listed, please contact PBN.
- (2) X2 used only in dual and quad transmitter versions
 - Dual version, X1 is first channel and X2 is the second channel.
 - Quad version, X1 is first channel and X2 is the fourth channel. The second is 200 GHz higher than the first. The third channel is 200 GHz higher from the second.

Examples:

Dual	X1X2	2527, 2525
Quad	X1X2	2531 (25, 27, 29, 31), 2525 (25, 25, 25, 25)

- (3) When order tunable lasers, write T in X1X2 option. T will apply to all ports (2 or 4).

Examples:

Tunable	X1X2	T
---------	------	---

Contact PBN Representatives for detailed optical channel information.

